

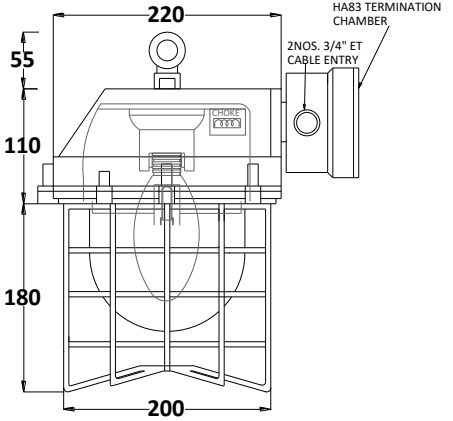

CATEGORY-HY

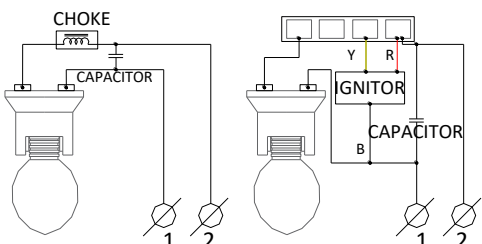





SPECIFICATION & QUOTATION FOR FLAME PROOF/W.PROOF LIGHT FITTINGS

CAST ALUMINIUM LM6 LIGHT FITTINGS DUST, VERMIN AND FLAMEPROOF /WEATHERPROOF SUITABLE FOR STRUCTURE MOUNTING. ALL THE ENCLOSURES ARE CAST OUT OF SUPERIOR QUALITY ALUMINUM ALLOYLM-6. ALL THE SURFACES ARE CAREFULLY CLEANED AND LEVELLED SO AS TO GIVE VERY SMOOTH SURFACE. ALL THE ENCLOSURES ARE CHROMATISED AND FINALLY EPOXY POWDER COATED BY STATIC CHARGE SPRAY METHOD BY LIGHT GREY SHADE 631 AS PER IS5. POWDER COATING GIVES VERY TOUGH DURABLE AND EXTREMELY SMOOTH SURFACE. ALL THE MATING SURFACES ARE PROVIDED WITH ROUND NEOPRENE RUBBER GASKET IN THE GROOVE SO AS TO MAKE IT EFFECTIVELY DUST AND VERMAIN PROOF. PRODUCTS ARE TESTED AT CIMFR-DHANBAD FOR FLAMEPROOF AND WEATHER PROOF TEST AS PER IS/IEC 60079-2007 FOR GAS GROUP IIA IIB IIC EXd-T6 AND WEATHER PROOF AS PER IS/IEC 60529-2001 FOR IP65 CLASS OF PROTECTION.OUR LIGHT FITTINGS ARE SUITABLE FOR OUTDOOR INSTALLATION WITHOUT ANY CANOPY.**MOUNTING:** AS SHOWN IN EACH ITEM **CABLE ENTRIES:** THREADED CABLE ENTRIES ARE PROVIDED. UNLESS OTHERWISE SPECIFIED NO GLAND WILL BE PROVIDED. **EARTHING:** EARTHING IS PROVIDED ON BOTH SIDES OF ENCLOSURES BY 5MM SCREW WITH TWO PLAIN WASHERS AND SPRING WASHER OF BRASS.

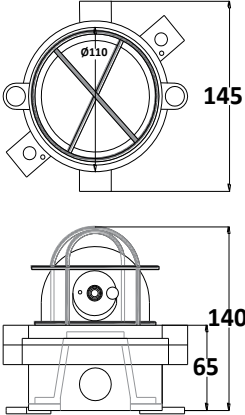

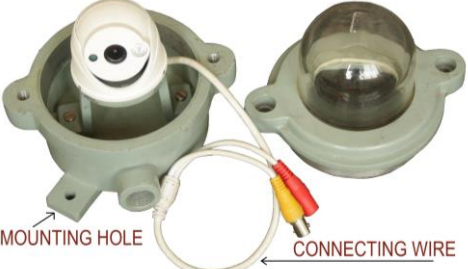

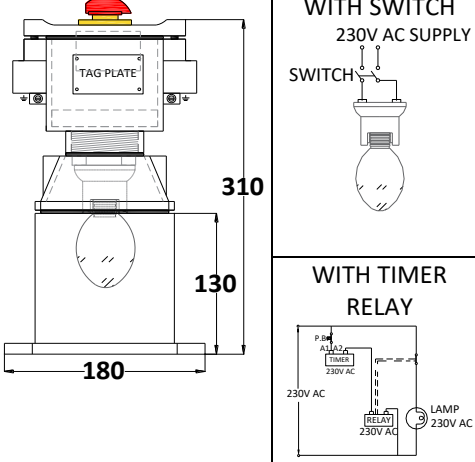

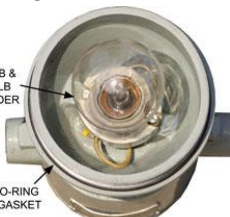
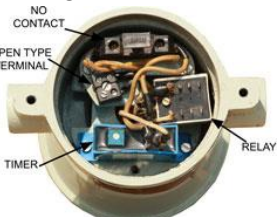
SPECIFIC REQUIREMENTS FOR WEATHERPROOF WELGLASS LIGHT FITTING

CODE	DRAWING	SPECIFICATION
<p>HY53</p>  <p>CML NO-7800010010</p>	 <p>HSN CODE: 94.05.20.90 BIS LICENCE NO-CML NO 7800010010 NOTE: IMAGES, DRAWING AND WIRING DIAGRAM ARE TYPICAL AND ACTUAL PRODUCT WILL BE AS PER ABOVE SPECIFICATION AND ORDER.</p>	<p>SUPPLY OF FLAMEPROOF/EXPLOSION PROOF WELGLASS LIGHT FITTING SUITABLE FOR HPMV/HPSV/MH BULB WITH SEPARATE TERMINATION CHAMBER. ENCLOSURE IS IN CAST ALUMINIUM LM-6 ALLOY, WITHOUT CANOPY, SUITABLE FOR INSTALLATION IN GAS GROUP AREA II A, IIB & IIC, IN ZONE 1, ZONE-2, Exd-T6, IP65 AS PER IS / IEC 60079-1-2007 & IP 65 CLASS OF PROTECTION AS PER IS/IEC 60529-2001. SUITABLE UPTO 125W HPMV/ 70W HPSV/70W MH BULB. IT IS PROVIDED WITH 125W HPMV WITH 10MFD CAPACITOR / 70W HPSV WITH 10MFD CAPACITOR WITH 70W HPSV LAMP IGNITOR / 70W MH WITH 15MFD CAPACITOR AND WITH LAMP IGNITOR & CHOKE WILL BE PROVIDED. PORCELIN THREADED HOLDER WILL BE PROVIDED. TOUGHENED FLP GLASS WITH WIRE GUARD & M.S J HOOK WILL BE PROVIDED WITH MS ZINK PLATED EYE BOLT PROVIDED AT THE TOP & TERMINATION CHAMBER WITH 4WAY 30A OPEN TYPE TERMINAL WILL BE PROVIDED. THICKNESS OF ENCLOSURE WILL BE 4-5MM IT WILL BE EPOXY POWDER COATED WITH 60 MICROS LIGHT GREY SHADE 631 AS PER IS-5. 3MM ROUND NEOPRENE RUBBER GASKET WILL BE PROVIDED IN COVER GROOVE. 2NOS. BRASS EARTHING BY ROUND HEAD NICKEL PLATED BRASS SCREWS WITH PLANE WASHER. COVER FIXING WILL BE BY 5NOS. M6 ALLEN BOLT. 2:3/4" ET CABLE ENTRIES WILL BE PROVIDED. TYPE: HY53.</p> <p>CIMFR CERTIFICATE NO. CIMFR/TC/P/H44 DT:29MAY 2017, PESO CERTIFICATE: P-402793</p>
	<p>WIRING DIAGRAM</p>  <p>WIRING DIAGRAM FOR 80/125W HPMV</p> <p>WIRING DIAGRAM FOR 70W HPSV OR 70W MH</p>	<p>FRONT VIEW</p>  <p>SIDE VIEW</p> 

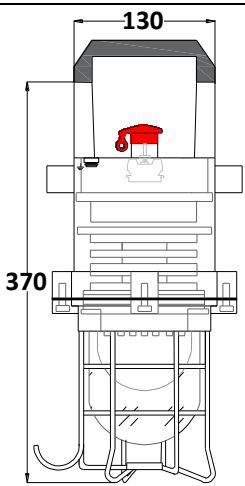
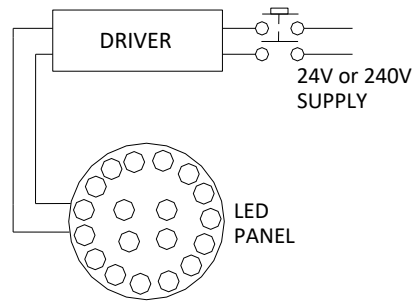

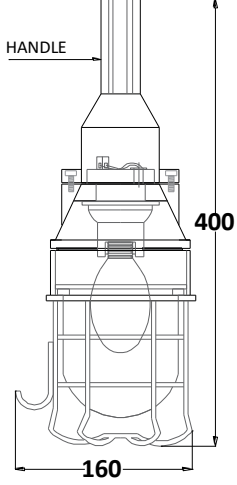
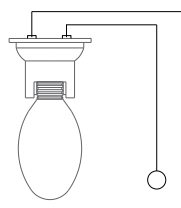



SPECIFIC REQUIREMENTS FOR WEATHERPROOF DAY-NIGHT VISION CAMERA

CODE	DRAWING	SPECIFICATION	
<p>HY54</p> 	 <p>CABLE ENTRY 2:3/4" ET</p> <p>HSN CODE: 94.05.20.90</p> <p>BIS LICENCE NO-CML NO 7800010010</p>	<p>SUPPLY OF FLAMEPROOF / WEATHERPROOF / EXPLOSION PROOF DAY NIGHT VISION CAMERA WITH IR HIGH RESOLUTION LENSE, SUITABLE FOR 12V DC SUPPLY. ENCLOSURE IS IN CAST ALUMINIUM LM-6 WITHOUT CANOPY SUITABLE FOR INSTALLATION IN GAS GROUP AREA II A, IIB & IIC, IN ZONE 1, ZONE-2, EXd-T6, IP65 AS PER IS / IEC 60079-1-2007 & IP 65 CLASS OF PROTECTION AS PER IS/IEC 60529-2001. BOROSILICATE FLP GLASS WILL BE PROVIDED. EXTERNAL LEGS ARE PROVIDED FOR WALL/STRUCTURAL MOUNTING. THICKNESS OF ENCLOSURE WILL BE 3-4MM IT WILL BE EPOXY POWDER COATED WITH 60 MICROS LIGHT GREY SHADE 631 AS PER IS-5. 3MM ROUND NEOPRENE RUBBER GASKET WILL BE PROVIDED IN COVER GROOVE. 2NOS. BRASS EARTHING BY ROUND HEAD NICKEL PLATED BRASS SCREWS WITH PLANE WASHER. COVER FIXING WILL BE BY 2NOS. 8MM ALLEN BOLT. 2:3/4" ET CABLE ENTRIES WILL BE PROVIDED.</p> <p>TYPE: HY54, PESO CERTIFICATE: P-402793</p> <p>CIMFR CERTIFICATE NO CIMFR/TC/P/H315 DT.23.02.2017,</p> <p>NOTE: IMAGES, DRAWING AND WIRING DIAGRAM ARE TYPICAL AND ACTUAL PRODUCT WILL BE AS PER ABOVE SPECIFICATION.</p>	
	<p>FRONT VIEW</p> 	<p>OPEN VIEW</p> 	
<p>HY55</p> 	 <p>WITH SWITCH 230V AC SUPPLY</p> <p>WITH TIMER RELAY</p>	<p>SUPPLY OF FLAMEPROOF/EXPLOSION PROOF REACTOR VESSEL LAMP FITTING WITHOUT CONTROL GEAR. CONSTRUCTED FROM DIE CAST ALUMINIUM ALLOY LM-6, SUITABLE FOR INSTALLATION IN-GROUP IIA, IIB GAS AREA SUITABLE UPTO 60W OR 16W CFL 240V LAMP, BUT WITHOUT BULB, SWITCH WILL BE IN SEPARATE CHAMBER AT THE TOP FOR EASE OF MAINTENANCE. LOOP IN LOOP OUT CAN BE DONE. 1:3/4" CABLE ENTRY WILL BE PROVIDED. TYPE: HY55</p> <p>HSN CODE: 94.05.20.90 PESO CERTIFICATE: P-402793</p> <p>BIS LICENCE NO-CML NO 7800010010</p> <p>NOTE: IMAGES, DRAWING AND WIRING DIAGRAM ARE TYPICAL AND ACTUAL PRODUCT WILL BE AS PER YOUR SPECIFICATION.</p>	
<p>FRONT VIEW</p> 	<p>SIDE VIEW</p> 	<p>OPEN VIEW 1</p> 	<p>OPEN VIEW 2</p> 

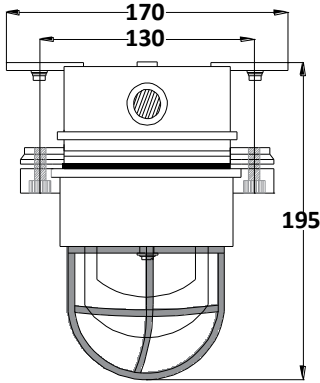
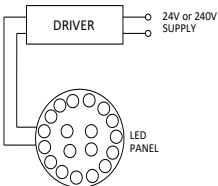



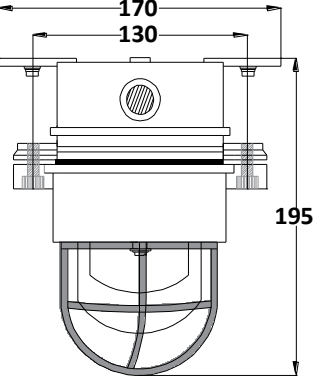
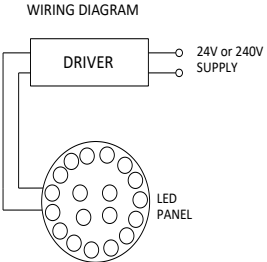

SPECIFIC REQUIREMENTS FOR WEATHERPROOF HAND LAMP/WELGLASS LIGHT FITTING

CODE	DRAWING	DESCRIPTION
<p>HY56</p>  <p>CML NO-7800010010</p>	 <p>HSN CODE: 94.05.20.90</p>	<p>SUPPLY OF FLAMEPROOF/EXPLOSION PROOF LED HAND LAMP LIGHT FITTING COMPLETE WITH CONTROL GEAR. CONSTRUCTED FROM DIE CAST ALUMINIUM ALLOY LM-6, ENCLOSURE IS IN CAST ALUMINIUM LM-6 ALLOY, WITHOUT CANOPY, SUITABLE FOR INSTALLATION IN GAS GROUP AREA II A, IIB & IIC, IN ZONE 1, ZONE-2, EXd-T6, IP65 AS PER IS / IEC 60079-1-2007 & IP 65 CLASS OF PROTECTION AS PER IS/IEC 60529-2001. SUITABLE UPTO 20 W LED LIGHT. IT IS PROVIDED WITH CONSTANT CURRENT LED DRIVER SUITABLE 24VAC INPUT AND OUT PUT WILL BE GIVEN TO UPTO 20NOS 1W EACH LED ON ALUMINIUM HEAT SINK. IT WILL BE PROVIDED WITH INSULATED HANDLE AT TOP. OPTIONAL ON-OFF SWITCH IS ALSO PROVIDED AT TOP. DIFFUSER IS PROVIDED TO SCATTER LIGHT IN ALL DIRECTIONS. LOOP IN LOOP OUT CAN BE DONE. BOROSILICATE GLASS WITH WIRE GUARD AND J HOOK ARE PROVIDED. THICKNESS OF ENCLOSURE 4-6MM. EPOXY POWDER COATED WITH 60 MICRONS LIGHT GRAY SHADE 631 AS PER IS5.3MM ROUND NEOPRENE RUBBER GASKET IN COVER GROOVE, 2NOS BRASS EARTHING BY ROUND HEAD NICKLE PLATED BRASS SCREWS WITH PLAIN WASHER AND SPRING WASHERS, COVER FIXING BY 8MM ALLEN BOLT. TYPE: HY56</p> <p>CIMFR CERTIFICATE NO CIMFR/TC/P/H355 DT 22.03.2017, PESO CERTIFICATE: P-402793 BIS LICENCE NO-CML NO 7800010010. NOTE: IMAGES, DRAWING AND WIRING DIAGRAM ARE TYPICAL AND ACTUAL PRODUCT WILL BE AS PER ABOVE SPEC.</p>
<div style="display: flex; justify-content: space-around;"> <div data-bbox="61 1028 625 1373"> <p>WIRING DIAGRAM STOP PB</p>  </div> <div data-bbox="625 1028 1006 1373"> <p>FRONT VIEW</p>  </div> <div data-bbox="1006 1028 1572 1373"> <p>OPEN VIEW</p>  </div> </div>		
<p>HY57</p>	 <p>HSN CODE: 94.05.20.90</p>	<p>SUPPLY OF FLAMEPROOF/EXPLOSION PROOF W. PROOF HAND LAMP FITTING WITHOUT CONTROL GEAR. CONSTRUCTED FROM DIE CAST ALUMINIUM ALLOY LM-6, SUITABLE FOR INSTALLATION IN-GROUP IIA, IIB GAS AREA SUITABLE FOR 60W 240V LAMP, BUT WITHOUT BULB TERMINATION WILL BE IN SEPARATE CHAMBER AT TOP FOR EASE OF MAINTENANCE. PORCELAINE LAMP HOLDER, WIRE GUARD WILL BE PROVIDED. BOROSIL TOUGHENED GLASS IS PROVIDED 1:3/4" CABLE ENTRY WILL BE PROVIDED. TYPE: HY57</p> <p>PESO CERTIFICATE: P-402793 BIS LICENCE NO-CML NO 7800010010. NOTE: IMAGES, DRAWING AND WIRING DIAGRAM ARE TYPICAL AND ACTUAL PRODUCT WILL BE AS PER ABOVE SPEC.</p> <div style="display: flex; justify-content: space-around;"> <div data-bbox="527 1733 787 2031"> <p>WIRING DIAGRAM</p>  </div> <div data-bbox="787 1733 1006 2031"> <p>FRONT VIEW</p>  </div> <div data-bbox="1006 1733 1234 2031"> <p>SIDE VIEW</p>  </div> <div data-bbox="1234 1733 1572 2031"> <p>OPEN VIEW</p>  </div> </div>

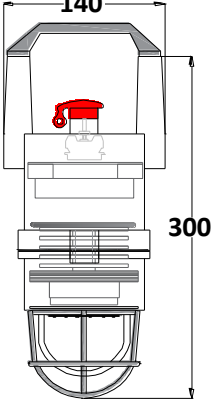



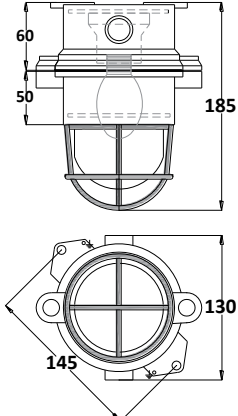

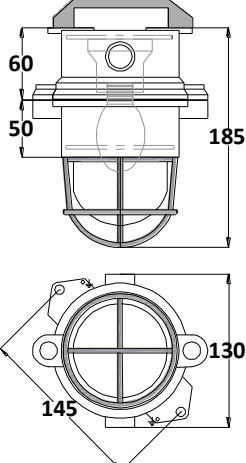

SPECIFIC REQUIREMENTS FOR WEATHERPROOF HANDLAMP/WELGLASS LIGHT FITTING

CODE	DRAWING	DESCRIPTION
<p>HY58</p>	 <p>HSN CODE: 94.05.20.90 BIS LICENCE NO-CML NO 7800010010 NOTE: IMAGES, DRAWING AND WIRING DIAGRAM ARE TYPICAL AND ACTUAL PRODUCT WILL BE AS PER ABOVE SPEC.</p>	<p>SUPPLY OF FLAMEPROOF/EXPLOSION PROOF LED 20 W LED TYPE WELGLASS WITHOUT SWITCH LIGHT FITTING COMPLETE WITH CONTROL GEAR. CONSTRUCTED FROM DIE. CAST ALUMINIUM ALLOY LM-6, ENCLOSURE IS IN CAST ALUMINIUM LM-6 ALLOY, WITHOUT CANOPY, SUITABLE FOR INSTALLATION IN GAS GROUP AREA II A, IIB & IIC, IN ZONE 1, ZONE-2, EXd-T6, IP65 AS PER IS / IEC 60079-1-2007 & IP 65 CLASS OF PROTECTION AS PER IS/IEC 60529-2001. SUITABLE UPTO 20 W LED LIGHT. IT IS PROVIDED WITH CONSTANT CURRENT LED DRIVER SUITABLE 24VAC INPUT AND OUT PUT WILL BE GIVEN TO UPTO 20NOS 1W EACH LED ON ALUMINIUM HEAT SINK. DIFFUSER IS PROVIDED TO SCATTER LIGHT IN ALL DIRECTIONS. LOOP IN LOOP OUT CAN BE DONE. BOROSILICATE GLASS WITH WIRE GUARD AND J HOOK ARE PROVIDED. THICKNESS OF ENCLOSURE 4-6MM. EPOXY POWDER COATED WITH 60 MICRONS LIGHT GRAY SHADE 631 AS PER IS5.3MM ROUND NEOPRENE RUBBER GASKET IN COVER GROOVE, 2NOS BRASS EARTHING BY ROUND HEAD NICKLE PLATED BRASS SCREWS WITH PLAIN WASHER AND SPRING WASHERS, COVER FIXING BY 8MM ALLEN BOLT. TYPES: HY58 PESO CERTIFICATE: P-402793 CIMFR CERTIFICATE NO CIMFR/TC/P/H355 DT 22.03.2017</p>
<p>WIRING DIAGRAM</p> 	<p>FRONT VIEW</p> 	<p>OPEN VIEW</p> 
<p>HY59</p>  <p>CML NO-7800010010</p>	 <p>HSN CODE: 94.05.20.90 BIS LICENCE NO-CML NO 7800010010 NOTE: IMAGES, DRAWING AND WIRING DIAGRAM ARE TYPICAL AND ACTUAL PRODUCT WILL BE AS PER ABOVE SPECIFICATION.</p>	<p>FLAMEPROOF/EXPLOSION PROOF 10W LED WEL GLASS TYPE LIGHT FITTING. ENCLOSURE IS IN CAST ALUMINIUM LM-6 ALLOY, WITHOUT CANOPY, SUITABLE FOR INSTALLATION IN GAS GROUP AREA II A, IIB & IIC, IN ZONE 1, ZONE-2, EXd-T6, IP65 AS PER IS / IEC 60079-1-2007 & IP 65 CLASS OF PROTECTION AS PER IS/IEC 60529-2001. SUITABLE UPTO 10 W LED LIGHT. IT IS PROVIDED WITH CONSTANT CURRENT LED DRIVER SUITABLE 24VAC INPUT AND OUT PUT WILL BE GIVEN TO UPTO 10NOS 1W EACH LED ON ALUMINIUM HEAT SINK.IT WILL BE PROVIDED, BOROSILICATE FLP GLASS WITH WIRE GUARD WILL BE PROVIDED. DIFFUSER IS PROVIDED TO SCATTER LIGHT IN ALL DIRECTIONS. EXTERNAL LEGS ARE PROVIDED FOR WALL / STRUCTURAL MOUNTING. THICKNESS OF ENCLOSURE WILL BE 3-4MM IT WILL BE EPOXY POWDER COATED WITH 60 MICROS LIGHT GREY SHADE 631 AS PER IS-5. 3MM ROUND NEOPRENE RUBBER GASKET WILL BE PROVIDED IN COVER GROOVE. 2NOS. BRASS EARTHING BY ROUND HEAD NICKEL PLATED BRASS SCREWS WITH PLANE WASHER. COVER FIXING WILL BE BY 2NOS. 8MM ALLEN BOLT. 2:3/4" ET CABLE ENTRIES WILL BE PROVIDED. TYPE: HY59 PESO CERTIFICATE: P-402793 CIMFR CERTIFICATE NO CIMFR/TC/P/H315 DT.23.02.2017,</p>
<p>WIRING DIAGRAM</p> 	<p>FRONT VIEW</p> 	<p>OPEN VIEW</p> 

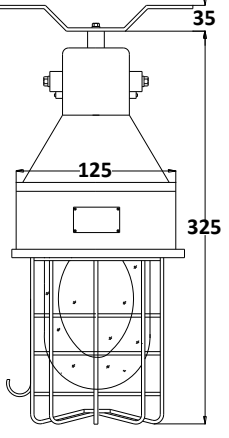
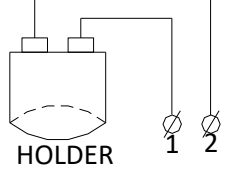

SPECIFIC REQUIREMENTS FOR WEATHERPROOF WELGLASS LIGHT FITTING

CODE	DRAWING	DESCRIPTION
<p>HY60</p>  <p>CML NO-7800010010</p>	 <p>HSN CODE: 94.05.20.90 BIS LICENCE NO-CML NO 7800010010 NOTE: IMAGES, DRAWING AND WIRING DIAGRAM ARE TYPICAL AND ACTUAL PRODUCT WILL BE AS PER ABOVE SPESIFICATION</p>	<p>SUPPLY OF FLAMEPROOF/EXPLOSION PROOF 10W HAND LAMP LIGHT FITTING. ENCLOSURE IS IN CAST ALUMINIUM LM-6 ALLOY, WITHOUT CANOPY, SUITABLE FOR INSTALLATION IN GAS GROUP AREA II A, IIB & IIC, IN ZONE 1, ZONE-2, EXD-T6, IP65 AS PER IS / IEC 60079-1-2007 & IP 65 CLASS OF PROTECTION AS PER IS/IEC 60529-2001. SUITABLE UPTO 10 W LED LIGHT. IT IS PROVIDED WITH CONSTANT CURRENT LED DRIVER SUITABLE 24VAC INPUT AND OUT PUT WILL BE GIVEN TO UPTO 10NOS 1W EACH LED ON ALUMINIUM HEAT SINK.IT WILL BE PROVIDED, BOROSILICATE FLP GLASS WITH WIRE GUARD WILL BE PROVIDED WITH INSULATED HANDLE AT TOP. OPTIONAL ON-OFF SWITCH IS ALSO PROVIDED AT TOP. DIFFUSER IS PROVIDED TO SCATTER LIGHT IN ALL DIRECTIONS. EXTERNAL LEGS ARE PROVIDED FOR WALL / STRUCTURAL MOUNTING. THICKNESS OF ENCLOSURE WILL BE 3-4MM IT WILL BE EPOXY POWDER COATED WITH 60 MICROS LIGHT GREY SHADE 631 AS PER IS-5. 3MM ROUND NEOPRENE RUBBER GASKET WILL BE PROVIDED IN COVER GROOVE. 2NOS. BRASS EARTHING BY ROUND HEAD NICKEL PLATED BRASS SCREWS WITH PLANE WASHER. COVER FIXING WILL BE BY 2NOS. 8MM ALLEN BOLT. 2:3/4" ET CABLE ENTRIES WILL BE PROVIDED.</p> <p>TYPE: HY60 PESO CERTIFICATE: P-402793 CIMFR CERTIFICATE NO CIMFR/TC/P/H315 DT.23.02.2017</p>
		
<p>HY61-W</p>  <p>CML NO-7800010010</p>	 <p>NOTE: IMAGES, DRAWING AND WIRING DIAGRAM ARE TYPICAL AND ACTUAL PRODUCT WILL BE AS PER ABOVE SPECIFICATION.</p>	<p>SUPPLY OF FLAMEPROOF/EXPLOSION PROOF 5W WELL GLASS LIGHT FITTING. ENCLOSURE IS IN CAST ALUMINIUM LM-6 ALLOY, WITHOUT CANOPY, SUITABLE FOR INSTALLATION IN GAS GROUP AREA II A, IIB & IIC, in ZONE 1, ZONE-2, EXd-T6, IP65 AS PER IS / IEC 60079-1-2007 & IP 65 CLASS OF PROTECTION AS PER IS/IEC 60529-2001. THREADED BULB HOLDER WILL BE PROVIDED WITHOUT BULB. BOROSILICATE FLP GLASS WITH WIRE GUARD WILL BE PROVIDED. EXTERNAL LEGS ARE PROVIDED FOR WALL / STRUCTURAL MOUNTING. THICKNESS OF ENCLOSURE WILL BE 3-4MM IT WILL BE EPOXY POWDER COATED WITH 60 MICROS LIGHT GREY SHADE 631 AS PER IS-5. 3MM ROUND NEOPRENE RUBBER GASKET WILL BE PROVIDED IN COVER GROOVE. 2NOS. BRASS EARTHING BY ROUND HEAD NICKEL PLATED BRASS SCREWS WITH PLANE WASHER. COVER FIXING WILL BE BY 2NOS. 8MM ALLEN BOLT. 2:3/4" ET CABLE ENTRIES WILL BE PROVIDED. HSN CODE: 94.05.20.90 TYPE: HY61-W BIS LICENCE NO-CML NO 7800010010, PESO CERTIFICATE: P-402793, CIMFR CERTIFICATE NO CIMFR/TC/P/H315 DT.23.02.2017</p>
<p>FRONT VIEW</p> 	<p>OPEN VIEW</p> 	

SPECIFIC REQUIREMENTS FOR EXPLOSION/WEATHERPROOF WELGLASSES

CODE	DRAWING	DESCRIPTION	
<p>HY61-H</p> 	 <p>HSN CODE: 94.05.20.90 IMAGES, DRAWING AND WIRING DIAGRAM ARE TYPICAL AND ACTUAL PRODUCT WILL BE AS PER ABOVE SPEC.</p>	<p>SUPPLY OF FLAMEPROOF/EXPLOSION PROOF 5W HAND LAMP LIGHT FITTING. ENCLOSURE IS IN CAST ALUMINIUM LM-6 ALLOY, WITHOUT CANOPY, SUITABLE FOR INSTALLATION IN GAS GROUP AREA II A, IIB & IIC, IN ZONE 1, ZONE-2, Exd-T6, IP65 AS PER IS / IEC 60079-1-2007 & IP 65 CLASS OF PROTECTION AS PER IS/IEC 60529-2001. THREADED BULB HOLDER WILL BE PROVIDED WITHOUT BULB. BOROSILICATE FLP GLASS WITH WIRE GUARD WILL BE PROVIDED. INSULATED HANDLE WILL BE PROVIDED AT THE TOP. EXTERNAL LEGS ARE PROVIDED FOR WALL / STRUCTURAL MOUNTING. THICKNESS OF ENCLOSURE WILL BE 3-4MM IT WILL BE EPOXY POWDER COATED WITH 60 MICROS LIGHT GREY SHADE 631 AS PER IS-5. 3MM ROUND NEOPRENE RUBBER GASKET WILL BE PROVIDED IN COVER GROOVE. 2NOS. BRASS EARTHING BY ROUND HEAD NICKEL PLATED BRASS SCREWS WITH PLANE WASHER. COVER FIXING WILL BE BY 2NOS. 8MM ALLEN BOLT. 2:3/4" ET CABLE ENTRIES WILL BE PROVIDED. TYPE: HY61-H BIS LICENCE NO-CML NO 7800010010 CIMFR CERTIFICATE NO CIMFR/TC/P/H315 DT.23.02.2017, PESO CERTIFICATE: P-402793</p>	
<p>FRONT VIEW WITH HANDLE</p> 	<p>OPEN VIEW WITH HANDLE REMOVED</p> 		
<p>HY62</p>	 <p>HSN CODE: 94.05.20.90</p>	<p>SUPPLY OF FLAMEPROOF/EXPLOSION PROOF WELL GLASS LIGHT FITTING WITHOUT CONTROL GEAR. CONSTRUCTED FROM DIE CAST ALUMINIUM ALLOY LM-6, SUITABLE FOR INSTALLATION IN GROUP IIA, IIB GAS AREA SUITABLE UPTO 60 W INCANDESCENT LAMP OR UPTO 16W CFL LAMP BUT WITHOUT BULB, SEPARATE TERMINAL CHAMBER AT THE TOP FOR EASE OF MAINTENANCE. LOOP IN LOOP OUT CAN BE DONE. BOROSIL GLASS WITH WIRE GUARD AND J HOOK ARE PROVIDED. TYPE: HY62, PESO CERTIFICATE: P-402793 BIS LICENCE NO-CML NO 7800010010. CIMFR CERTIFICATE NO CIMFR/TC/P/H-315 DT.23.02.2017, NOTE: IMAGES, DRAWING AND WIRING DIAGRAM ARE TYPICAL AND ACTUAL PRODUCT WILL BE AS PER ABOVE SPEC.</p>	
 <p>HOLDER</p>	<p>FRONT VIEW</p> 	<p>SIDE VIEW</p> 	<p>OPEN VIEW</p> 

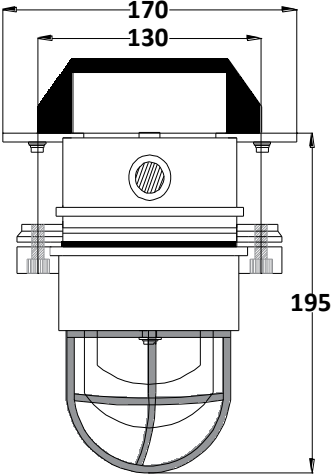
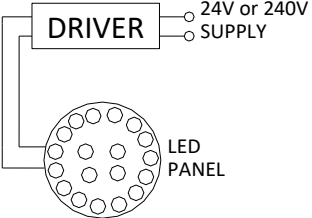
SPECIFIC REQUIREMENTS FOR EXPLOSION/WEATHERPROOF WELGLASSES

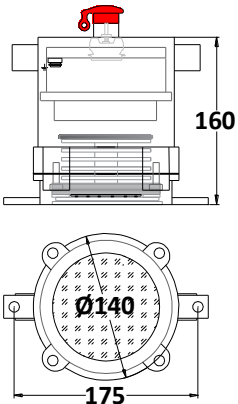
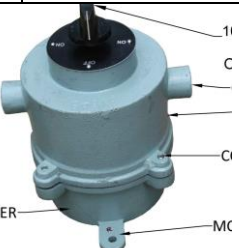
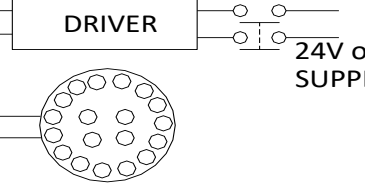
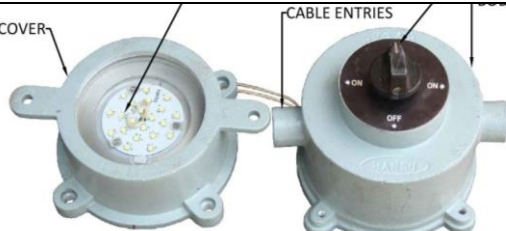
CODE	DRAWING	DESCRIPTION
HY63  <small>CML NO-7800010010</small>	 <p>HSN CODE: 94.05.20.90 NOTE: IMAGES, DRAWING AND WIRING DIAGRAM ARE TYPICAL AND ACTUAL PRODUCT WILL BE AS PER ABOVE SPEC.</p>	<p>SUPPLY OF FLAMEPROOF/EXPLOSION PROOF 20W HAND LAMP LIGHT FITTING WITHOUT SWITCH. ENCLOSURE IS IN CAST ALUMINIUM LM-6 ALLOY, WITHOUT CANOPY, SUITABLE FOR INSTALLATION IN GAS GROUP AREA II A, IIB & IIC, IN ZONE 1, ZONE-2, EXD-T6, IP65 AS PER IS / IEC 60079-1-2007 & IP 65 CLASS OF PROTECTION AS PER IS/IEC 60529-2001. SUITABLE UPTO 20 W LED LIGHT. IT IS PROVIDED WITH CONSTANT CURRENT LED DRIVER SUITABLE 240V OR 24VAC INPUT AND OUT PUT WILL BE GIVEN TO UPTO 20NOS 1W EACH LED ON ALUMINIUM HEAT SINK. IT WILL BE PROVIDED, DIFFUSER IS PROVIDED TO SCATTER LIGHT IN ALL DIRECTIONS. BOROSILICATE FLP GLASS WITH WIRE GUARD WILL BE PROVIDED WITH INSULATED HANDLE AT TOP. EXTERNAL LEGS ARE PROVIDED FOR WALL / STRUCTURAL MOUNTING. THICKNESS OF ENCLOSURE WILL BE 3-4MM IT WILL BE EPOXY POWDER COATED WITH 60 MICROS LIGHT GREY SHADE 631 AS PER IS-5. 3MM ROUND NEOPRENE RUBBER GASKET WILL BE PROVIDED IN COVER GROOVE. 2NOS. BRASS EARTHING BY ROUND HEAD NICKEL PLATED BRASS SCREWS WITH PLANE WASHER. COVER FIXING WILL BE BY 2NOS. 8MM ALLEN BOLT. 2:3/4" ET CABLE ENTRIES WILL BE PROVIDED. TYPE: HY63, BIS LICENCE NO-CML NO 7800010010 CIMFR CERTIFICATE NO CIMFR/TC/P/H355 DT.22.03.2017, PESO CERTIFICATE: P-402793,</p>
WIRING DIAGRAM	FRONT VIEW	OPEN VIEW
		
HY64	 <p>NOTE: IMAGES, DRAWING AND WIRING DIAGRAM ARE TYPICAL AND ACTUAL PRODUCT WILL BE AS PER ABOVE SPECIFICATION.</p>	<p>SUPPLY OF FLAMEPROOF/EXPLOSION PROOF REACTOR VESSEL LAMP LIGHT FITTING COMPLETE WITH CONTROL GEAR. CONSTRUCTED FROM DIE CAST ALUMINIUM ALLOY LM-6, SUITABLE FOR INSTALLATION IN GROUP IIA, IIB IIC GAS GROUP AREA SUITABLE UPTO 20 W LED LIGHT. IT IS PROVIDED WITH CONSTANT CURRENT LED DRIVER SUITABLE 24VAC INPUT AND OUT PUT WILL BE GIVEN 20 – 22W, 1W EACH LED ON ALUMINIUM HEAT SINK. ON-OFF SWITCH IS ALSO PROVIDED AT TOP. LOOP IN LOOP OUT CAN BE DONE. BOROSILICATE GLASS WITH WIRE GUARD AND J HOOK ARE PROVIDED. THICKNESS OF ENCLOSURE 4-6MM. EPOXY POWDER COATED WITH 60 MICRONS LIGHT GRAY SHADE 631 AS PER IS. 3MM ROUND NEOPRENE RUBBER GASKET IN COVER GROOVE, 2NOS BRASS EARTHING BY ROUND HEAD NICKLE PLATED BRASS SCREWS WITH PLAIN WASHER AND SPRING WASHERS, COVER FIXING BY 8MM ALLEN BOLT. HSN CODE: 94.05.20.90 TYPE: HY64 BIS LICENCE NO-CML NO 7800010010, PESO CERTIFICATE: P-402793, CIMFR CERTIFICATE NO CIMFR/TC/P/H355 DT 22.03.2017,</p>
WIRING DIAGRAM	2P SWITCH	
		

SPECIFIC REQUIREMENTS FOR EXPLOSION/WEATHERPROOF WELGLASSES

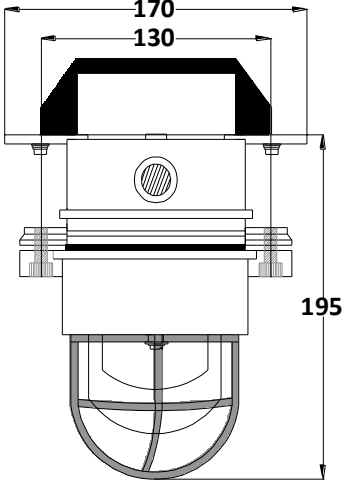
CODE	DRAWING	DESCRIPTION
<p>HY65</p> 	 <p>HSN CODE: 94.05.20.90</p>	<p>SUPPLY OF FLAMEPROOF/EXPLOSION PROOF 10W HAND LAMP LIGHT FITTING. ENCLOSURE IS IN CAST ALUMINIUM LM-6 ALLOY, WITHOUT CANOPY, SUITABLE FOR INSTALLATION IN GAS GROUP AREA II A, IIB & IIC, IN ZONE 1, ZONE-2, Exd-T6, IP65 AS PER IS / IEC 60079-1-2007 & IP 65 CLASS OF PROTECTION AS PER IS/IEC 60529-2001. SUITABLE UPTO 10 W LED LIGHT. IT IS PROVIDED WITH CONSTANT CURRENT LED DRIVER SUITABLE 24VAC INPUT AND OUT PUT WILL BE GIVEN TO UPTO 10NOS 1W EACH LED ON ALUMINIUM HEAT SINK. IT WILL BE PROVIDED DIFFUSER IS PROVIDED TO SCATTER LIGHT IN ALL DIRECTIONS. BOROSILICATE FLP GLASS WITH WIRE GUARD WILL BE PROVIDED WITH INSULATED HANDLE AT TOP. EXTERNAL LEGS ARE PROVIDED FOR WALL / STRUCTURAL MOUNTING. THICKNESS OF ENCLOSURE WILL BE 3-4MM IT WILL BE EPOXY POWDER COATED WITH 60 MICROS LIGHT GREY SHADE 631 AS PER IS-5. 3MM ROUND NEOPRENE RUBBER GASKET WILL BE PROVIDED IN COVER GROOVE. 2NOS. BRASS EARTHING BY ROUND HEAD NICKEL PLATED BRASS SCREWS WITH PLANE WASHER. COVER FIXING WILL BE BY 2NOS. 8MM ALLEN BOLT. 2:3/4" ET CABLE ENTRIES WILL BE PROVIDED.</p> <p>TYPE: HY65 PESO CERTIFICATE: P-402793 CIMFR CERTIFICATE NO CIMFR/TC/P/H315 DT.23.02.2017, BIS LICENCE NO-CML NO 780001001</p> <p>NOTE: IMAGES, DRAWING AND WIRING DIAGRAM ARE TYPICAL AND ACTUAL PRODUCT WILL BE AS PER ABOVE SPECIFICATION.</p>

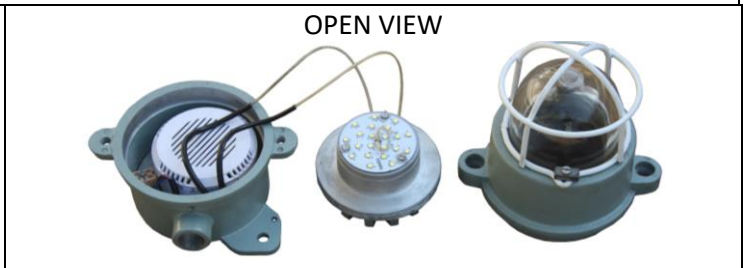
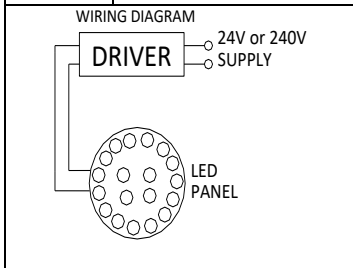

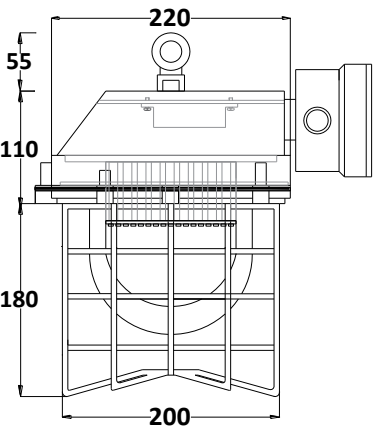



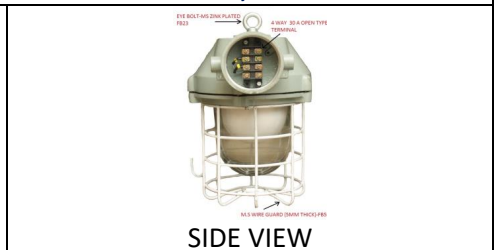
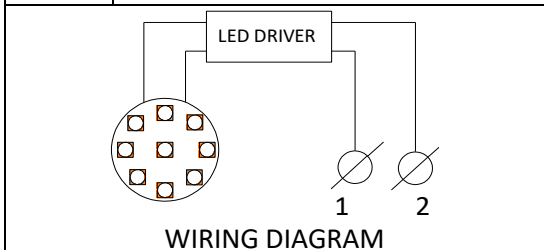

<p>HY66</p> 	 <p>HSN CODE: 94.05.20.90</p> <p>NOTE: IMAGES, DRAWING AND WIRING DIAGRAM ARE TYPICAL AND ACTUAL PRODUCT WILL BE AS PER ABOVE SPECIFICATION.</p>
---	---

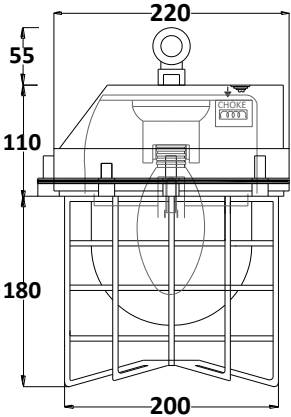
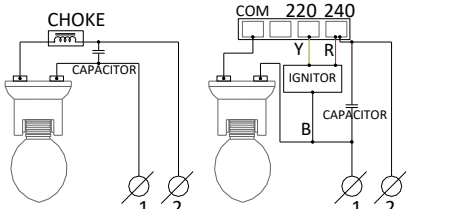



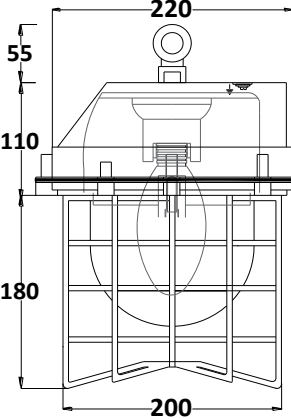
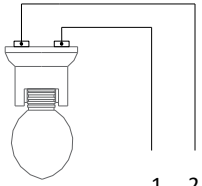

SUPPLY OF FLAMEPROOF/EXPLOSION PROOF 30/40/45/50/60W LED WELGLASS LIGHT FITTING WITH SEPARATE TERMINATION CHAMBER. ENCLOSURE IS IN CAST ALUMINIUM LM-6 ALLOY, WITHOUT CANOPY, SUITABLE FOR INSTALLATION IN GAS GROUP AREA II A, IIB & IIC, IN ZONE 1, ZONE-2, EXd-T6, IP65 AS PER IS / IEC 60079-1-2007 & IP 65 CLASS OF PROTECTION AS PER IS/IEC 60529-2001. SUITABLE UPTO 30/40/45/50/60W LED LIGHT. IT IS PROVIDED WITH CONSTANT CURRENT LED DRIVER, LED CIRCUIT ON ALUMINIUM HEAT SINK. IT WILL BE PROVIDED DIFFUSER IS PROVIDED TO SCATTER LIGHT IN ALL DIRECTIONS. TOUGHENED FLP GLASS WITH WIRE GUARD & M.S J HOOK WILL BE PROVIDED WITH MS ZINK PLATED EYE BOLT PROVIDED AT THE TOP & TERMINATION CHAMBER WITH 4WAY 30A OPEN TYPE TERMINAL WILL BE PROVIDED. THICKNESS OF ENCLOSURE WILL BE 4-5MM IT WILL BE EPOXY POWDER COATED WITH 60 MICROS LIGHT GREY SHADE 631 AS PER IS-5. 3MM ROUND NEOPRENE RUBBER GASKET WILL BE PROVIDED IN COVER GROOVE. 2NOS. BRASS EARTHING BY ROUND HEAD NICKEL PLATED BRASS SCREWS WITH PLANE WASHER. COVER FIXING WILL BE BY 5NOS. M6 ALLEN BOLT. 2:3/4" ET CABLE ENTRIES WILL BE PROVIDED. **TYPE: HY66 PESO CERTIFICATE: P-402793.**
BIS LICENCE NO-CML NO 7800010010
CIMFR CERTIFICATE NO. CIMFR/TC/P/H44 DT:29 MAY 2017,



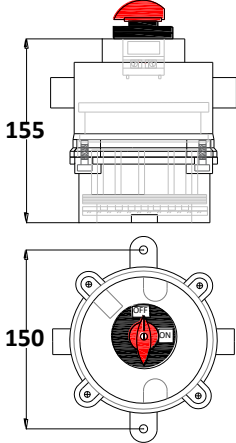
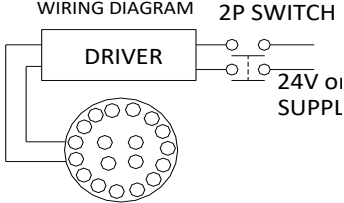

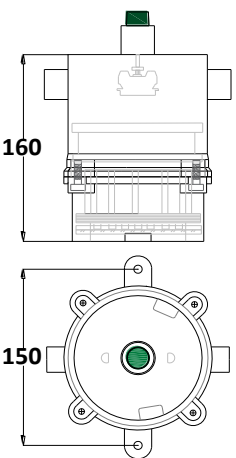
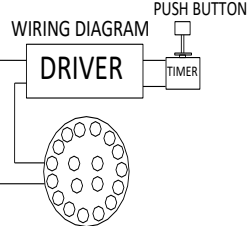

SPECIFIC REQUIREMENTS FOR EXPLOSION/WEATHERPROOF WELGLASSES

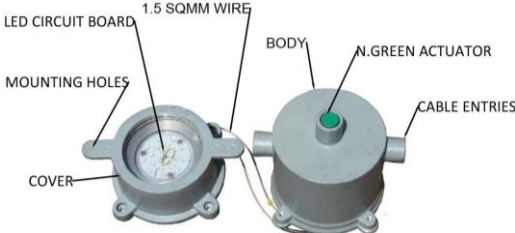
CODE	DRAWING	DESCRIPTION
<p>HY67</p>  <p>CML NO-7800010010</p>	 <p>HSN CODE: 94.05.20.90</p> <p>NOTE: IMAGES, DRAWING AND WIRING DIAGRAM ARE TYPICAL AND ACTUAL PRODUCT WILL BE AS PER ABOVE SPECIFICATION.</p>	<p>SUPPLY OF DIRECT ENTRY FLAMEPROOF/EXPLOSION PROOF WELGLASS LIGHT FITTING SUITABLE FOR HPMV/HPSV/MH BULB. ENCLOSURE IS IN CAST ALUMINIUM LM-6 ALLOY, WITHOUT CANOPY, SUITABLE FOR INSTALLATION IN GAS GROUP AREA II A, IIB & IIC, IN ZONE 1, ZONE-2, EXd-T6, IP65 AS PER IS / IEC 60079-1-2007 & IP 65 CLASS OF PROTECTION AS PER IS/IEC 60529-2001. SUITABLE UPTO 125W HPMV/ 70W HPSV/70W MH BULB. 125W HPMV WITH 10MFD CAPACITOR / 70W HPSV WITH 10MFD CAPACITOR WITH 70W HPSV LAMP IGNITOR / 70W MH WITH 15MFD CAPACITOR AND WITH LAMP IGNITOR & CHOKE WILL BE PROVIDED. PORCELEIN THREADED HOLDER WILL BE PROVIDED. TOUGHENED FLP GLASS WITH WIRE GUARD & M.S J HOOK WILL BE PROVIDED WITH MS ZINK PLATED EYE BOLT PROVIDED AT THE TOP. THICKNESS OF ENCLOSURE WILL BE 4-5MM IT WILL BE EPOXY POWDER COATED WITH 60 MICROS LIGHT GREY SHADE 631 AS PER IS-5. 3MM ROUND NEOPRENE RUBBER GASKET WILL BE PROVIDED IN COVER GROOVE. 2NOS. BRASS EARTHING BY ROUND HEAD NICKEL PLATED BRASS SCREWS WITH PLANE WASHER. COVER FIXING WILL BE BY 5NOS. M6 ALLEN BOLT. 2:3/4" ET CABLE ENTRIES WILL BE PROVIDED. TYPE: HY67. BIS LICENCE NO-CML NO 7800010010 CIMFR CERTIFICATE NO. CIMFR/TC/P/H44 DT:29 MAY 2017, PESO CERTIFICATE: P-402793.</p>
<p>WIRING DIAGRAM</p>  <p>WIRING DIAGRAM FOR 80/125W HPMV</p> <p>WIRING DIAGRAM FOR 70W HPSV OR 70W MH</p>	<p>FRONT VIEW</p> 	<p>SIDE VIEW</p> 
<p>HY68</p>  <p>CML NO-7800010010</p>	 <p>HSN CODE: 94.05.20.90</p> <p>NOTE: IMAGES, DRAWING AND WIRING DIAGRAM ARE TYPICAL AND ACTUAL PRODUCT WILL BE AS PER ABOVE SPECIFICATION.</p>	<p>SUPPLY OF DIRECT ENTRY FLAMEPROOF/EXPLOSION PROOF WELGLASS LIGHT FITTING SUITABLE UPTO 200W GLS OR 45W CFL BULB. ENCLOSURE IS IN CAST ALUMINIUM LM-6 ALLOY, WITHOUT CANOPY, SUITABLE FOR INSTALLATION IN GAS GROUP AREA II A, IIB & IIC, IN ZONE 1, ZONE-2, EXd-T6, IP65 AS PER IS / IEC 60079-1-2007 & IP 65 CLASS OF PROTECTION AS PER IS/IEC 60529-2001. SUITABLE UPTO 200W GLS/ 45W CFL BULB WITH PORCELEIN THREADED HOLDER WILL BE PROVIDED. TOUGHENED FLP GLASS WITH WIRE GUARD & M.S J HOOK WILL BE PROVIDED WITH MS ZINK PLATED EYE BOLT PROVIDED AT THE TOP. THICKNESS OF ENCLOSURE WILL BE 4-5MM IT WILL BE EPOXY POWDER COATED WITH 60 MICROS LIGHT GREY SHADE 631 AS PER IS-5. 3MM ROUND NEOPRENE RUBBER GASKET WILL BE PROVIDED IN COVER GROOVE. 2NOS. BRASS EARTHING BY ROUND HEAD NICKEL PLATED BRASS SCREWS WITH PLANE WASHER. COVER FIXING WILL BE BY 5NOS. M6 ALLEN BOLT. 2:3/4" ET CABLE ENTRIES WILL BE PROVIDED. TYPE: HY68. BIS LICENCE NO-CML NO 7800010010, CIMFR CERTIFICATE NO. CIMFR/TC/P/H44 DT:29 MAY 2017, PESO CERTIFICATE: P-402793.</p>
 <p>DIRECT TERMINATION FOR 200W GLS OR 45W CFL</p> <p>WIRING DIAGRAM</p>	<p>FRONT VIEW</p> 	<p>SIDE VIEW</p> 



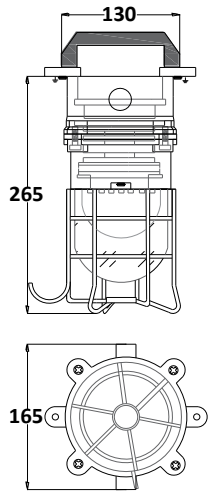
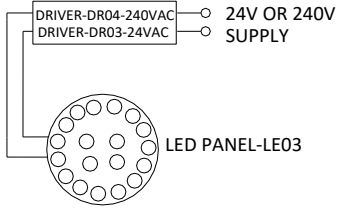
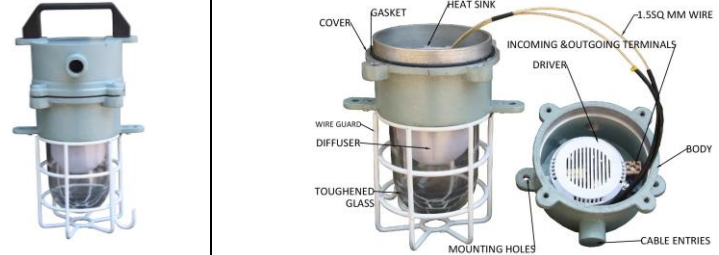

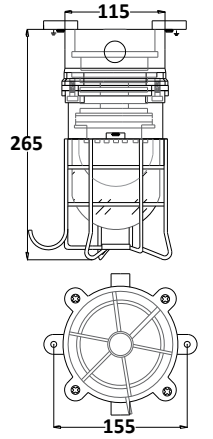
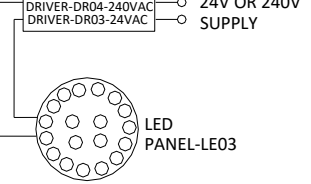
SPECIFIC REQUIREMENTS FOR EXPLOSION/WEATHERPROOF LIGHTS

CODE	DRAWING	DESCRIPTION
<p>HY71-S</p> 	 <p>HSN CODE: 94.05.20.90</p> <p>NOTE: IMAGES, DRAWING AND WIRING DIAGRAM ARE TYPICAL AND ACTUAL PRODUCT WILL BE AS PER ABOVE SPECIFICATION.</p>	<p>SUPPLY OF FLAMEPROOF/EXPLOSION PROOF REACTOR VESSEL LAMP WITH SWITCH. CONSTRUCTED FROM DIE CAST ALUMINIUM ALLOY LM-6, SUITABLE FOR INSTALLATION IN GROUP IIA, IIB IIC GAS GROUP AREA IN ZONE 1, ZONE-2, EXd-T6, IP66 AS PER IS / IEC 60079-1-2007, GROUP IIIA, IIIB IIIC GAS GROUP AREA IN ZONE 21, ZONE-22, EXt-T6, IP66 AS PER IS / IEC 60079-31-2013 & IP 66 CLASS OF PROTECTION AS PER IS/IEC 60529-2001 AND SUITABLE UPTO 40 W LED LIGHT. IT IS PROVIDED WITH CONSTANT CURRENT LED DRIVER SUITABLE 24VAC OR 240V AC INPUT AND OUT PUT WILL BE GIVEN 35 – 42W, 1W EACH LED ON ALUMINIUM HEAT SINK. 10A CAM TYPE ON OFF SWITCH IS ALSO PROVIDED AT TOP. LOOP IN LOOP OUT CAN BE DONE. BOROSILICATE TOUGHENED GLASS IS PROVIDED. THICKNESS OF ENCLOSURE 4-6MM. EPOXY POWDER COATED WITH 60 MICRONS LIGHT GRAY SHADE 631 AS PER IS5.3MM ROUND NEOPRENE RUBBER GASKET IN COVER GROOVE, 2 NOS BRASS EARTHING BY ROUND HEAD NICKLE PLATED BRASS SCREWS WITH PLAIN WASHER AND SPRING WASHERS, COVER FIXING BY 8MM ALLEN BOLT.</p> <p>TYPE: HY71-S PESO CERTIFICATE: P-402793</p> <p>BIS LICENCE NO-CML NO 7800010010</p> <p>CERTIFICATE-NO-CIMFR/TC/P/H76 DT.18.06.2019</p>
<p>WIRING DIAGRAM</p> 		
<p>HY72-T</p> 	 <p>HSN CODE: 94.05.20.90</p> <p>NOTE: IMAGES, DRAWING AND WIRING DIAGRAM ARE TYPICAL AND ACTUAL PRODUCT WILL BE AS PER ABOVE SPECIFICATION.</p>	<p>SUPPLY OF FLAMEPROOF/EXPLOSION PROOF REACTOR VESSEL LAMP LIGHT FITTING COMPLETE WITH TIMER. CONSTRUCTED FROM DIE CAST ALUMINIUM ALLOY LM-6, SUITABLE FOR INSTALLATION IN GROUP IIA, IIB IIC GAS GROUP AREA IN ZONE 1, ZONE-2, EXd-T6, IP66 AS PER IS / IEC 60079-1-2007, GROUP IIIA, IIIB IIIC GAS GROUP AREA IN ZONE 21, ZONE-22, EXt-T6, IP66 AS PER IS / IEC 60079-31-2013 & IP 66 CLASS OF PROTECTION AS PER IS/IEC 60529-2001 AND UPTO 40 W LED LIGHT. IT IS PROVIDED WITH CONSTANT CURRENT LED DRIVER SUITABLE 24VAC OR 240V AC INPUT AND OUT PUT WILL BE GIVEN 35 – 42, 1W EACH LED ON ALUMINIUM HEAT SINK. N. GREEN ACTUATOR AND TIMER FOR 240V AC OR 24V AC IS PROVIDED SUCH THAT IF BUTTON IS PRESSED LIGHT WILL BE ON FOR PRESET TIME AND WILL GO OFF AUTOMATICALLY AFTER SET TIME. YOU MAY PRESS BUTTON ONCE AGAIN TO GET LIGHT. LOOP IN LOOP OUT CAN BE DONE. BOROSILICATE TOUGHENED GLASS IS PROVIDED. THICKNESS OF ENCLOSURE 4-6MM. EPOXY POWDER COATED WITH 60 MICRONS LIGHT GRAY SHADE 631 AS PER IS5.3MM ROUND NEOPRENE RUBBER GASKET IN COVER GROOVE, 2 NOS BRASS EARTHING BY ROUND HEAD NICKLE PLATED BRASS SCREWS WITH PLAIN WASHER AND SPRING WASHERS, COVER FIXING BY 8MM ALLEN BOLT.</p> <p>TYPE: HY72-T,</p> <p>BIS LICENCE NO-CML NO 7800010010,</p> <p>PESO CERTIFICATE: P-402793, CIMFR/TC/P/H76 DT.18.06.2019</p>
<p>WIRING DIAGRAM</p>  <p>WIRING DIAGRAM</p>		

SPECIFIC REQUIREMENTS FOR EXPLOSION/WEATHERPROOF FLOOD LIGHT

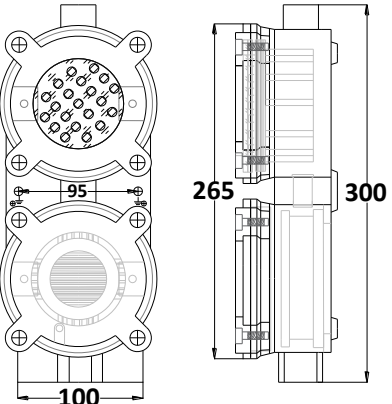
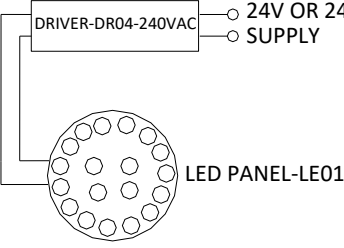
CODE	DRAWING	DESCRIPTION
<p>HY73</p> 	 <p>HSN CODE: 94.05.20.90 BIS LICENCE NO-CML NO 7800010010 NOTE: IMG, DRG AND WIRING DIA. ARE TYPICAL AND ACTUAL PRODUCT WILL BE AS PER ABOVE SPEC.</p>	<p>SUPPLY OF FLAMEPROOF/EXPLOSION PROOF UPTO 40W LED HAND LAMP. ENCLOSURE IS IN CAST ALUMINIUM LM-6 ALLOY, WITHOUT CANOPY, SUITABLE FOR INSTALLATION IN GROUP IIA, IIB IIC GAS GROUP AREA IN ZONE 1, ZONE-2, EXd-T6, IP66 AS PER IS / IEC 60079-1-2007, GROUP IIIA, IIIB IIIC GAS GROUP AREA IN ZONE 21, ZONE-22, EXt-T6, IP66 AS PER IS / IEC 60079-31-2013 & IP 66 CLASS OF PROTECTION AS PER IS/IEC 60529-2001. SUITABLE UPTO 40 W LED LAMP. IT IS PROVIDED WITH CONSTANT CURRENT LED DRIVER SUITABLE 240VAC INPUT AND OUT PUT WILL BE GIVEN TO UPTO 35-42NOS 1W EACH LED ON ALUMINIUM HEAT SINK. IT WILL BE PROVIDED DIFFUSER IS PROVIDED TO SCATTER LIGHT IN ALL DIRECTIONS. BOROSILICATE FLP GLASS WITH WIRE GUARD WILL BE PROVIDED WITH INSULATED HANDLE AT TOP. THICKNESS OF ENCLOSURE WILL BE 3-4MM IT WILL BE EPOXY POWDER COATED WITH 60 MICROS LIGHT GREY SHADE 631 AS PER IS-5. 3MM ROUND NEOPRENE RUBBER GASKET WILL BE PROVIDED IN COVER GROOVE. 2NOS. BRASS EARTHING BY ROUND HEAD NICKEL PLATED BRASS SCREWS WITH PLANE WASHER. COVER FIXING WILL BE BY 2NOS. 8MM ALLEN BOLT. 2:3/4" ET CABLE ENTRIES WILL BE PROVIDED.</p> <p>TYPE-HY73 PESO CERTIFICATE: P-402793, CMRI CERTIFICATE -CIMFR/TC/P/H76 DT.18.06.2019</p>
		
<p>HY74-W</p> 	 <p>HSN CODE: 94.05.20.90 BIS LICENCE NO-CML NO 7800010010 NOTE: IMAGES, DRAWING AND WIRING DIAGRAM ARE TYPICAL AND ACTUAL PRODUCT WILL BE AS PER ABOVE SPECIFICATION.</p>	<p>SUPPLY OF FLAMEPROOF/EXPLOSION PROOF UPTO 40W LED WELGLASS. ENCLOSURE IS IN CAST ALUMINIUM LM-6 ALLOY, WITHOUT CANOPY, SUITABLE FOR INSTALLATION IN GROUP IIA, IIB IIC GAS GROUP AREA IN ZONE 1, ZONE-2, EXd-T6, IP66 AS PER IS / IEC 60079-1-2007, GROUP IIIA, IIIB IIIC GAS GROUP AREA IN ZONE 21, ZONE-22, EXt-T6, IP66 AS PER IS / IEC 60079-31-2013 & IP 66 CLASS OF PROTECTION AS PER IS/IEC 60529-2001. SUITABLE UPTO 40 W LED WELGLASS. IT IS PROVIDED WITH CONSTANT CURRENT LED DRIVER SUITABLE 240VAC INPUT AND OUT PUT WILL BE GIVEN TO UPTO 42NOS 1W EACH LED ON ALUMINIUM HEAT SINK. IT WILL BE PROVIDED DIFFUSER IS PROVIDED TO SCATTER LIGHT IN ALL DIRECTIONS. BOROSILICATE FLP GLASS WITH WIRE GUARD. EXTERNAL LEGS ARE PROVIDED FOR WALL / STRUCTURAL MOUNTING. THICKNESS OF ENCLOSURE WILL BE 3-4MM IT WILL BE EPOXY POWDER COATED WITH 60 MICROS LIGHT GREY SHADE 631 AS PER IS-5. 3MM ROUND NEOPRENE RUBBER GASKET WILL BE PROVIDED IN COVER GROOVE. 2NOS. BRASS EARTHING BY ROUND HEAD NICKEL PLATED BRASS SCREWS WITH PLANE WASHER. COVER FIXING WILL BE BY 4NOS. 8MM ALLEN BOLT. 2:3/4" ET CABLE ENTRIES WILL BE PROVIDED.</p> <p>TYPE-HY74-W PESO CERTIFICATE: P-402793, CMRI CERTIFICATE -CIMFR/TC/P/H76 DT.18.06.2019</p>
	 <p>WIRING DIAGRAM</p>	

SPECIFIC REQUIREMENTS FOR EXPLOSION/WEATHERPROOF FLOOD LIGHT

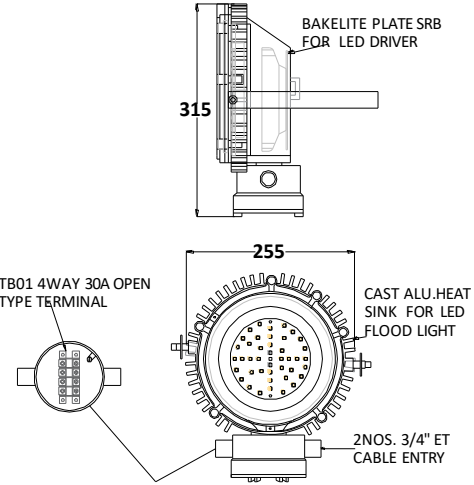
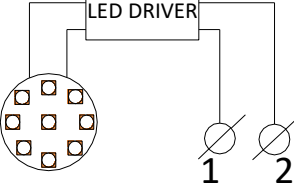
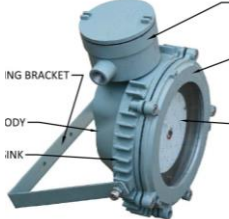
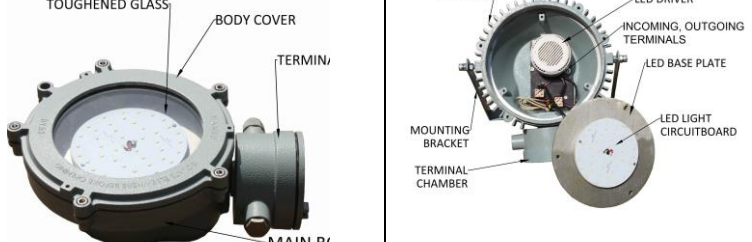
CODE	DRAWING	DESCRIPTION
<p>HY75</p> 	 <p>HSN CODE: 94.05.20.9 BIS LICENCE NO-CML NO 7800010010 NOTE: IMAGES, DRAWING AND WIRING DIAGRAM ARE TYPICAL AND ACTUAL PRODUCT WILL BE AS PER ABOVE SPEC.</p>	<p>SUPPLY OF FLAMEPROOF/EXPLOSION PROOF UPTO 40W BULKHEAD/STREET LIGHT/SIGNAL LIGHT. ENCLOSURE IS IN CAST ALUMINIUM LM-6 ALLOY, WITHOUT CANOPY, SUITABLE FOR INSTALLATION IN GAS GROUP AREA II A, IIB & IIC, IN ZONE 1, ZONE-2, EXd-T6, IP66 AS PER IS / IEC 60079-1-2007 & IP 66 CLASS OF PROTECTION AS PER IS/IEC 60529-2001. SUITABLE UPTO 40 W BULKHEAD/STREET LIGHT/SIGNAL LIGHT. IT IS PROVIDED WITH CONSTANT CURRENT LED DRIVER SUITABLE 240VAC INPUT AND OUT PUT WILL BE GIVEN TO UPTO 42NOS 1W EACH LED ON ALUMINIUM HEAT SINK. BOROSILICATE TOUGHENED GLASS IS PROVIDED. EXTERNAL LEGS ARE PROVIDED FOR WALL / STRUCTURAL MOUNTING. THICKNESS OF ENCLOSURE WILL BE 3-4MM IT WILL BE EPOXY POWDER COATED WITH 60 MICROS LIGHT GREY SHADE 631 AS PER IS-5. 3MM ROUND NEOPRENE RUBBER GASKET WILL BE PROVIDED IN COVER GROOVE. 2NOS. BRASS EARTHING BY ROUND HEAD NICKEL PLATED BRASS SCREWS WITH PLANE WASHER. COVER FIXING WILL BE BY 8NOS. 8MM ALLEN BOLT. 2:3/4" ET CABLE ENTRIES WILL BE PROVIDED. TYPE: HY75 PESO CERTIFICATE: P-402793, CMRI CERTIFICATE -CIMFR/TC/P/H31 DT.07.05.2019</p>
 <p>WIRING DIAGRAM</p>		
<p>HY76</p> 	 <p>HSN CODE: 94.05.20.90 BIS LICENCE NO-CML NO 7800010010 NOTE: IMAGES, DRAWING AND WIRING DIAGRAM ARE TYPICAL AND ACTUAL PRODUCT WILL BE AS PER ABOVE SPEC.</p>	<p>SUPPLY OF FLAMEPROOF/EXPLOSION PROOF 50/60/70/80/90W LED FLOOD/BULKHEAD LIGHT FITTING WITH SEPARATE TERMINATION CHAMBER. ENCLOSURE IS IN CAST ALUMINIUM LM-6 ALLOY, WITHOUT CANOPY, SUITABLE FOR INSTALLATION IN GAS GROUP AREA II A, IIB & IIC, IN ZONE 1, ZONE-2, EXd-T6, IP66 AS PER IS / IEC 60079-1-2007 & IP 66 CLASS OF PROTECTION AS PER IS/IEC 60529-2001. SUITABLE UPTO 50/60/70/80/90W LED LIGHT. IT IS PROVIDED WITH CONSTANT CURRENT. LED DRIVER, LED CIRCUIT ON ALUMINIUM HEAT SINK. TOUGHENED FLAT FLP GLASS WILL BE PROVIDED. IT WILL BE FURTHER PROVIDED WITH MS POWDER COATED BRACKET FOR MOUNTING ON WALL OR ON STRUCTURE & WITH FACILITY TO CHANGE THE ANGLE. TERMINATION CHAMBER WITH 4WAY 30A OPEN TYPE TERMINAL WILL BE PROVIDED. THICKNESS OF ENCLOSURE WILL BE 4-5MM IT WILL BE EPOXY POWDER COATED WITH 60 MICROS LIGHT GREY SHADE 631 AS PER IS-5. 3MM ROUND NEOPRENE RUBBER GASKET WILL BE PROVIDED IN COVER GROOVE. 2NOS. BRASS EARTHING BY ROUND HEAD NICKEL PLATED BRASS SCREWS WITH PLANE WASHER. COVER FIXING WILL BE BY 5NOS. M6 ALLEN BOLT. 2:3/4" ET CABLE ENTRIES WILL BE PROVIDED. TYPE: HY76 CMRI CERTIFICATE- CIMFR/TC/P/H22 DT.15.04.2019 PESO CERTIFICATE: P-402793.</p>
 <p>WIRING DIAGRAM</p>	 <p>FRONT VIEW</p>	

SPECIFIC REQUIREMENTS FOR EXPLOSION/WEATHERPROOF FLOOD LIGHT/BULKHEAD LIGHT

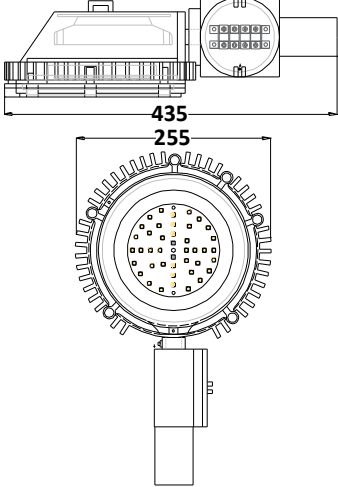
CODE	DRAWING	DESCRIPTION
<p>HY77</p> 	 <p>HSN CODE: 94.05.20.90 BIS LICENCE NO-CML NO 7800010010 IMAGES, DRAWING AND WIRING DIA ARE TYPICAL AND ACTUAL PRODUCT WILL BE AS PER ABOVE SPEC</p>	<p>SUPPLY OF FLAMEPROOF/EXPLOSION PROOF LED TYPE STREET LIGHT UPTO 90W WITH SEPARATE TERMINATION CHAMBER. ENCLOSURE IS IN CAST ALUMINIUM LM-6 ALLOY, WITHOUT CANOPY, SUITABLE FOR INSTALLATION IN GAS GROUP AREA II A, IIB & IIC, IN ZONE 1, ZONE-2, Exd-T6, IP66 AS PER IS / IEC 60079-1-2007 & IP 66 CLASS OF PROTECTION AS PER IS/IEC 60529-2001. SUITABLE UPTO 90W LED LIGHT. IT IS PROVIDED WITH CONSTANT CURRENT. LED DRIVER, LED CIRCUIT ON ALUMINIUM HEAT SINK. TOUGHENED FLAT FLP GLASS WILL BE PROVIDED. IT WILL BE FURTHER PROVIDED WITH MS POWDER COATED BRACKET FOR MOUNTING ON WALL OR ON STRUCTURE & WITH FACILITY TO CHANGE THE ANGLE. TERMINATION CHAMBER WITH 4WAY 30A OPEN TYPE TERMINAL WILL BE PROVIDED. THICKNESS OF ENCLOSURE WILL BE 4-5MM IT WILL BE EPOXY POWDER COATED WITH 60 MICROS LIGHT GREY SHADE 631 AS PER IS-5. 3MM ROUND NEOPRENE RUBBER GASKET WILL BE PROVIDED IN COVER GROOVE. 2NOS. BRASS EARTHING BY ROUND HEAD NICKEL PLATED BRASS SCREWS WITH PLANE WASHER. COVER FIXING WILL BE BY 5NOS. M6 ALLEN BOLT. 2:3/4" ET CABLE ENTRIES WILL BE PROVIDED. TYPE: HY77 CMRI TC-CIMFR/TC/P/H22 DT.15.04.2019, PESO CERTIFICATE: P-402793</p>

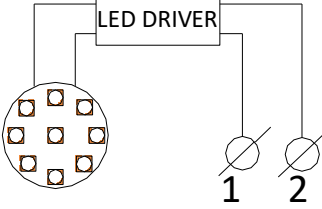
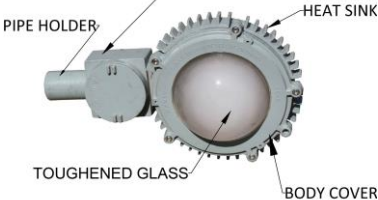
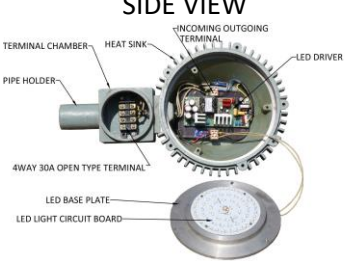
 <p>WIRING DIAGRAM</p>	<p>FRONT VIEW</p> 	<p>SIDE VIEW</p> 
---	--	---

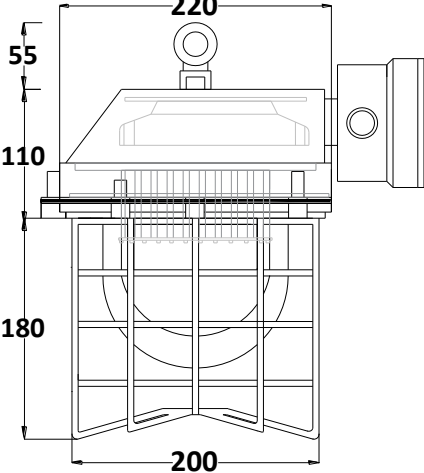
<p>HY78</p> 	 <p>HSN CODE: 94.05.20.90 BIS LICENCE-CML NO 7800010010 IMAGES, DRG AND WIRING DIAGRAM ARE TYPICAL AND ACTUAL PRODUCT WILL BE AS PER ABOVE DESCRIPTION.</p>	<p>SUPPLY OF FLAMEPROOF/EXPLOSION PROOF 90W LED WELGLASS LIGHT FITTING WITH SEPARATE TERMINATION CHAMBER. ENCLOSURE IS IN CAST ALUMINIUM LM-6 ALLOY, WITHOUT CANOPY, SUITABLE FOR INSTALLATION IN GAS GROUP AREA II A, IIB & IIC, IN ZONE 1, ZONE-2, Exd-T6, IP66 AS PER IS / IEC 60079-1-2007 & IP 66 CLASS OF PROTECTION AS PER IS/IEC 60529-2001. SUITABLE FOR 90W LED LIGHT. IT IS PROVIDED WITH CONSTANT CURRENT. LED DRIVER, LED CIRCUIT ON ALUMINIUM HEAT SINK. IT WILL BE PROVIDED DIFFUSER IS PROVIDED TO SCATTER LIGHT IN ALL DIRECTIONS. TOUGHENED FLP GLASS WITH WIRE GUARD & M.S J HOOK WILL BE PROVIDED WITH MS ZINK PLATED EYE BOLT PROVIDED AT THE TOP & TERMINATION CHAMBER WITH 4WAY 30A OPEN TYPE TERMINAL WILL BE PROVIDED. THICKNESS OF ENCLOSURE WILL BE 4-5MM IT WILL BE EPOXY POWDER COATED WITH 60 MICROS LIGHT GREY SHADE 631 AS PER IS-5. 3MM ROUND NEOPRENE RUBBER GASKET WILL BE PROVIDED IN COVER GROOVE. 2NOS. BRASS EARTHING BY ROUND HEAD NICKEL PLATED BRASS SCREWS WITH PLANE WASHER. COVER FIXING WILL BE BY 5NOS. M6 ALLEN BOLT. 2:3/4" ET CABLE ENTRIES WILL BE PROVIDED. TYPE: HY78 CMRI TC-CIMFR/TC/P/H02 DT.05.04.2019, PESO CERTIFICATE: P-402793.</p>
---	---	---

		
---	---	---